

Take Control.
ION
Controllers



Ion®

Digital Level Control Switch

- Rated for use in both sump and sewage pump applications
- Will work with any 115 volt pump up to 15 amps
- Solid state sensing technology with no moving parts to wear or fail
- Designed to operate for over 2 million cycles
- Longer pumping differential means it will pump more water less frequently
- 20 foot cord



37 Forestwood Dr., Romeoville, IL 60446 www.ionproducts.net [815] 886-9200

Patent No. 8,591,198

Assembly View

1. Cord strain relief follower
2. Mounting arm screw
3. Switch mounting arm
4. Top housing
5. Control and logic boards
6. Switch bracket
7. Strain gauge
8. Pressure plate
9. Diaphragm with integrated o-ring gasket
10. Diaphragm guard

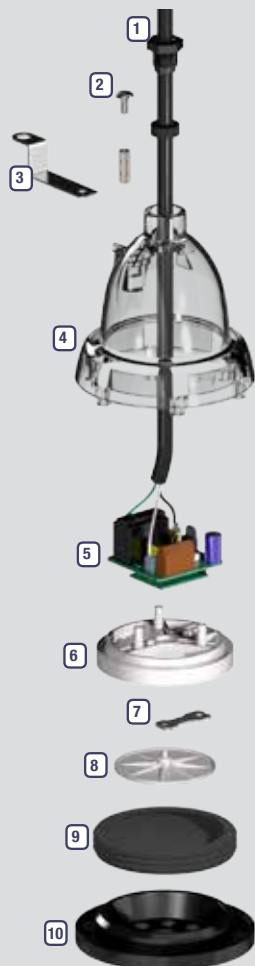

Switch Dimensions

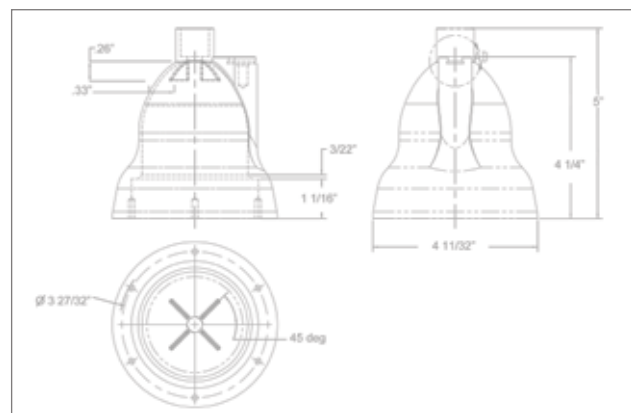

Piggyback Plug Illustration

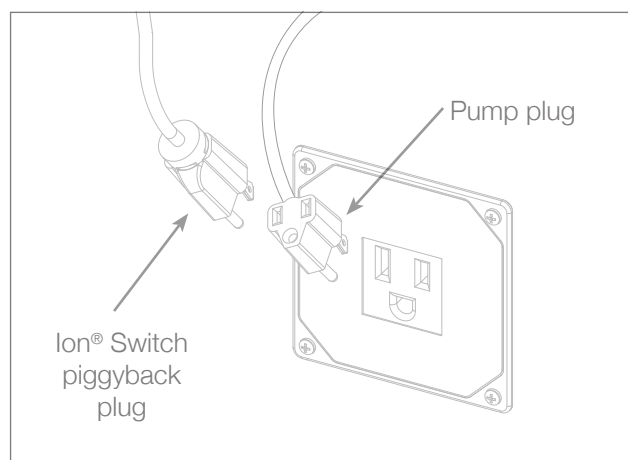

System Specifications

- Type of Application: Sump and sewage
- Voltage: 115 volt
- Amp Rating: 13 FLA, 15 amp max
- Power Cord: 20'
- Pump Range: 6" or 8.5"
- 3 year warranty

Distributed By:
Jim Murray, Inc.
 N116 W18455 Morse Drive
 Germantown, WI 53022
 800-234-5490
www.jimmurrayinc.com
sales@jimmurrayinc.com