

**PVL-MAX-SFS**  
Automatic  
**PVL-ULTRA-MAN**  
Manual

**INTRODUCTION**

This instruction sheet will provide you with information required to safely own and operate Jim Murray, Inc. MAX Series pumps. The pump you have purchased is a submersible effluent pump for use in basins, effluent, wastewater and other non-explosive, non-corrosive liquids with up to 1/2" spherical solids.

The Jim Murray, Inc. MAX Series unit you have purchased is of the highest quality workmanship and material. It has been engineered to give you long and trouble-free service.

The Jim Murray, Inc. MAX Series pumps are carefully packaged, inspected and tested to insure safe operation and delivery. When you receive your pump, examine it carefully to determine that there are no broken or damaged parts that may have occurred during shipment. If damage has occurred, make notation and notify the firm that you purchased the pump from. They will assist you in replacement or repair, if required.

**READ INSTRUCTIONS CAREFULLY BEFORE ATTEMPTING TO INSTALL, OPERATE OR SERVICE THE JIM MURRAY, INC. MAX SERIES PUMP. KNOW THE PUMP APPLICATION, LIMITATIONS, AND POTENTIAL HAZARDS. PROTECT YOURSELF AND OTHERS BY OBSERVING ALL SAFETY INFORMATION. FAILURE TO COMPLY WITH INSTRUCTIONS COULD RESULT IN PERSONAL INJURY AND/OR PROPERTY DAMAGE! RETAIN INSTRUCTIONS FOR FUTURE REFERENCE.**

**SAFETY GUIDELINES**



1. Make certain pump is disconnected from power source before attempting to service or remove any component.
2. Do not use to pump flammable or explosive fluids such as gasoline, fuel oil, kerosene, etc. DO NOT use in explosive atmospheres or hazardous locations as classified by NEC, ANSI/NFPAT. Pump should be used with liquids compatible with pump component materials.
3. Do not handle the pump with wet hands or when standing on a wet or damp surface or in water.
4. Do not pull the pump out of the water by the power cord when the pump is operating or connected to power source.
5. This pump is supplied with a grounding conductor and/or grounding type attachment plug. To reduce the risk of electrical shock, be certain that it is connected to a properly grounded grounding type receptacle.
6. The National Electric Code requires a ground fault circuit interrupter (GFCI) be installed in the branch circuit supplying fountain equipment, pools, etc.
7. **In any installation where property damage and/or personal injury might result from an inoperative or leaking pump due to power outages, discharge line blockage, or any other reason, a backup system(s) and/or alarm should be used.**

8. Support pump and piping when assembling and when installed. Failure to do so may cause piping to break, pump to fail, motor bearing failures, etc.
9. This pump's motor housing is filled with a dielectric oil for motor heat transfer and lifetime lubrication of the bearings. This oil is non-toxic to aquatic life. However, suffocation can occur if oil is left on the water surface. If oil escapes the motor housing it can be removed from the surface quickly by placing newspapers on the water surface to soak up the oil.
10. The pump motor is equipped with an automatic resetting thermal protector and may restart unexpectedly. Protector tripping is an indication of motor overloading as a result of excessively high or low voltage, inadequate wiring, incorrect motor connections, or a defective motor or pump.

**ELECTRICAL CONNECTIONS**



1. Check the pump label for proper voltage required. Do not connect to voltage other than that shown.
2. If pump is supplied with a 3-prong electrical plug, the third prong is to ground the pump to prevent possible electrical shock hazard. DO NOT REMOVE the third prong from the plug. A separate branch circuit is recommended. Do not use an extension cord. Do not cut plug from the cord. If the plug is cut or the cord is shortened, then this action will void the warranty.
3. If the cord is equipped with stripped lead wires, such as on 230V models, be sure that the lead wires are connected to a power source correctly. The (green/yellow) wire is the ground. The (blue or white) and (brown or black) are live.
4. Check local electrical and building codes before installation. The installation must be in accordance with their regulations as well as the most recent National Electrical Code (NEC).
5. To conform to the National Electrical Code, all pumps must be wired with 14 AWG or larger wire. For runs to 250', 14 AWG wire is sufficient. For longer runs, consult a qualified electrician or the factory.
6. Pump should be connected or wired to its own circuit with no other outlets or equipment in the circuit line. Fuses and circuit breaker should be of ample capacity in the electrical circuit.
7. The flexible PVC jacketed cord assembly mounted to the pump must not be modified in any way, with the exception of shortening the cord to fit into a control panel. Any splice between the pump and the control panel must be made within a junction box and mounted outside of the basin and comply with the National Electrical Code.

**CONSULT INSTRUCTION SHEET ILLUSTRATIONS FOR PROPER ASSEMBLY AND DISASSEMBLY OF YOUR JIM MURRAY, INC. MAX SERIES PUMP.**

**OPERATION**

1. Pump must be installed in a suitable basin which is at least 18" in diameter and 22" deep. Check and follow local plumbing codes.
2. Pump features a 1-1/2" female NPT discharge.
3. Clean debris and inspect basin and sump for obstructions. Pump must be placed on a hard level surface. Never place pump directly on clay, earth or gravel surfaces. Clean any sediment, mud or sand from basin.
4. A check valve should be used in the discharge line to prevent back flow of liquid into the basin. The check valve should be a free-flow valve that will easily pass solids.

**CAUTION:** For best performance of check valves when handling solids, install in a horizontal position or at an angle of no more than 45°.

5. Do not attempt to restrict the intake side of these pumps. Restricting the intake may cause damage to the seal and may starve the pump. If you require reduced flow rates, then place a valve on the discharge side of the pump or if flexible vinyl tubing is used, a clamp can be used on the tubing to restrict the flow.
6. Do not let the unit run dry (without liquid). It is designed to be cooled by pumping fluid. You may damage the seal and the motor may fail if the pump is allowed to run dry.
7. If the unit is going to be idle for a period of time, follow the cleaning instructions outlined in the next section. Do not let the unit freeze in the wintertime. This may cause cracking or distortion that may destroy the unit.

### TESTING PUMP OPERATION

#### PVL-MAX-SFS AUTOMATIC

1. These pumps are equipped with a float operated mechanical switch.
2. When these pumps are installed in a basin with a sealed cover, switch operation cannot be observed. The sump cover usually will have a spare that is plugged with a rubber plug. This plug can be removed and switch operation can be observed.
3. Plug power cord into a grounded receptacle with voltage consistent with pump voltage as indicated on pump nameplate.
4. Run water into pump until pump starts.
5. Be sure gate valve in discharge line is open.
6. Allow pump to operate through several on off cycles.

#### PVL-ULTRA-MAN MANUAL

1. The pump cord for these pumps can be plugged directly into a properly grounded receptacle with voltage consistent with pump nameplate for continuous pump operation.

**CAUTION:** This type of operation should be used only for emergency use or when a large volume of water is to be pumped. Pump must not be allowed to run dry. If pump is run dry, it may damage pump and void the warranty.

### SERVICE INSTRUCTIONS



**MAKE CERTAIN THE UNIT IS DISCONNECTED FROM THE POWER SOURCE BEFORE ATTEMPTING TO SERVICE OR REMOVE ANY COMPONENT!**

1. If pump does not operate properly, consult the troubleshooting chart. If trouble cannot be located with these steps shown, consult your pump dealer or installer (plumber).
2. This unit is permanently lubricated. Oiling is not required. Do not, in any case, open the sealed portion of the unit or remove housing screws.
3. Periodic cleaning of the pump parts will prolong the LIFE and EFFICIENCY of the pump. Refer to the assembly and disassembly of the pumping head.
4. Remove screws that hold base to volute and clean impeller and volute passage. Do not use strong solvents on impeller.
5. Be sure impeller turns freely after cleaning.
6. **WARNING: DO NOT REMOVE IMPELLER. REMOVAL OF IMPELLER REQUIRES SPECIAL TOOLS AND IS TO BE DONE ONLY BY AN AUTHORIZED SERVICE CENTER. DO NOT REMOVE MOTOR HOUSING COVER. WARRANTY IS VOID IF MOTOR HOUSING COVER, IMPELLER OR SEALS HAVE BEEN REMOVED.**
7. Be certain power cord is in good condition and contains no nicks or cuts.

TROUBLESHOOTING INFORMATION		
PROBLEM	PROBABLE CAUSES	CORRECTIVE ACTION
Pump does not turn on.	Pump not plugged in.	Plug in pump.
	Circuit breaker shutoff or fuse removed.	Turn on circuit breaker or replace fuse.
	Accumulation of trash on float.	Clean float.
	Float obstruction.	Check float path and provide clearance.
	Defective switch.	Have pump serviced by authorized service center.
	Defective motor.	Have pump serviced by authorized service center.
Pump will not shut off.	Float or float rod obstruction.	Check float and float rod path and provide clearance.
	Pump is air locked.	Shut power off for approximately 1 minute, then restart. Repeat several times to clear air from pump.
	Liquid inflow matches pump capacity.	Larger pump required.
	Defective switch.	Disconnect switch, check w/ohmmeter, Open-infinite resistance, closed-zero.
Pump runs but does not discharge liquid.	Check valve installed backwards.	Check flow indicating arrow on check valve body to insure it is installed properly.
	Check valve stuck or plugged.	Remove check valve and inspect for proper operation.
	Lift too high for pump.	Check rating table.
	Inlet to impeller plugged.	Pull pump and clean.
	Pump is air locked.	(See corrective action above.)
Pump does not deliver rated capacity.	Lift too high for pump.	Check rated pump performance.
	Low voltage, speed too slow.	Check for proper supply voltage to make certain it corresponds to nameplate voltage.
	Impeller or discharge pipe is clogged.	Pull pump and clean. Check pipe for scale or corrosion.
Pump cycles continually.	Impeller wear due to abrasives.	Replace worn impeller.
	No check valve in long discharge pipe allowing liquid to drain back into sump.	Install a check valve in discharge line.
	Check valve leaking.	Inspect check valve for correct operation.
	Basin too small for inflow.	Install larger basin.

**Figure 1. Typical Installation**

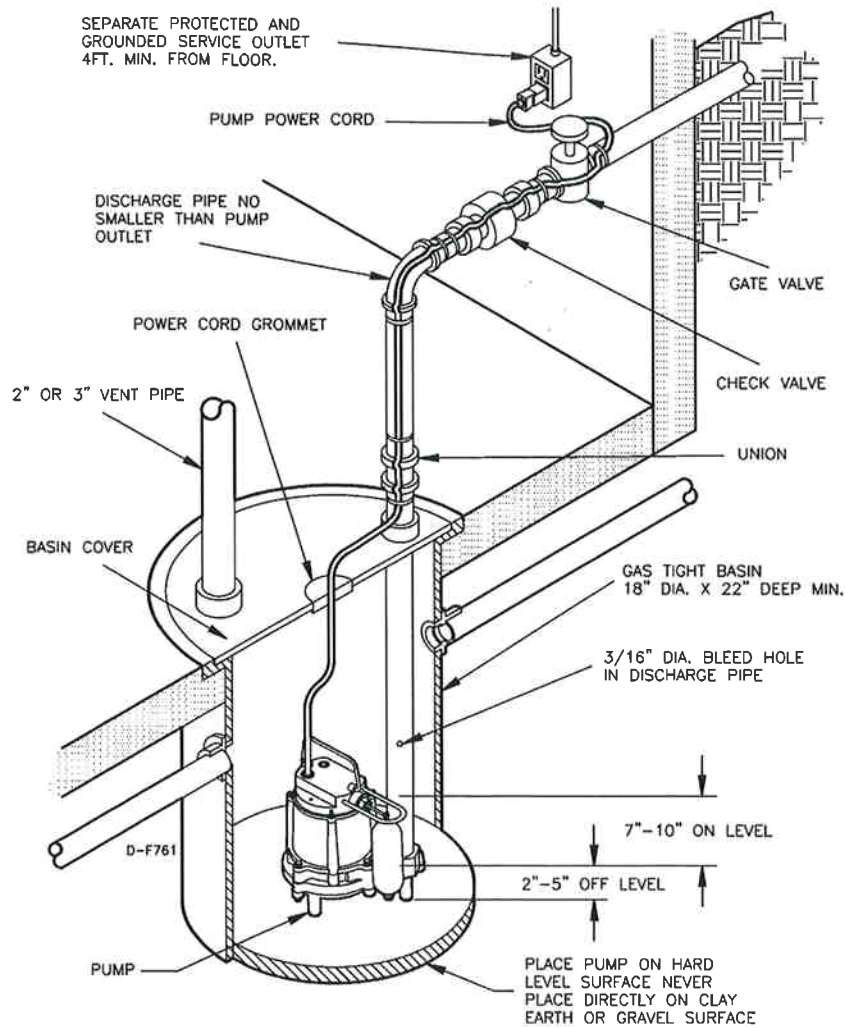

**THREE (3) YEAR LIMITED WARRANTY  
SUMP, EFFLUENT, & RESIDENTIAL SEWAGE  
INTRODUCTION**

Jim Murray, Inc. MAX Series pumps are recommended for use in sumps, basins or lift stations and suitable for pumping basement drainage water, effluent, wastewater and other non-explosive, non-corrosive, non-abrasive liquids not above 140°F with 1/2" solids handling ability. (NOT TO BE USED FOR SEWAGE WATER EXCEPT TO PUMP SEPTIC TANK EFFLUENT.)

Jim Murray, Inc. MAX Series pumps are guaranteed to be in perfect condition when they leave our factory. During the time periods and subject to the conditions hereinafter set forth, Jim Murray, Inc. will repair or replace to the original user or consumer any portion of your new Jim Murray, Inc. product which proves defective due to materials or workmanship of Jim Murray, Inc. Contact your nearest Jim Murray, Inc. dealer for warranty service. At all times Jim Murray, Inc. shall have and possess the sole right and option to determine whether to repair or replace defective equipment, parts, or components. Damage due to lightning or conditions beyond the control of Jim Murray, Inc. is NOT COVERED BY THIS WARRANTY.

**WARRANTY PERIOD**

**PUMPS:** 36 months from date of purchase.

**LABOR, ETC. COSTS:** Jim Murray, Inc. shall IN NO EVENT be responsible or liable for the cost of field labor or other charges incurred by any customer in removing and/or affixing any Jim Murray, Inc. product, part or component thereof.

**THIS WARRANTY WILL NOT APPLY:**

- 1) to defects or malfunctions resulting from failure to properly install, operate, or maintain the unit in accordance with printed instructions provided.
- 2) to failures resulting from abuse, accident or negligence.
- 3) to normal maintenance services and the parts used in connection with such service
- 4) to units which are not installed in accordance with applicable local codes, ordinances and good trade practices.
- 5) unit is used for purposes other than for what it was designed and manufactured.
- 6) If pump exposed to but not limited to the following: sand, gravel, cement, grease, plaster, mud, tar, hydrocarbons, or hydrocarbon derivatives (oil, gasoline, solvents, etc.) or other abrasive or corrosive substances.

- 7) if pump has been used for continuous pumping of suitable liquids above 140°F.
- 8) if power cord has been cut or spliced
- 9) if pump has been dismantled by customer. (Dealer only can dismantle pump for field service.)

**RETURN OR REPLACED COMPONENTS:** Any item to be replaced under the Warranty must be returned to Jim Murray, Inc. or such other place as Jim Murray, Inc. may designate, freight prepaid.

**PRODUCT IMPROVEMENTS:** Jim Murray, Inc. reserves the right to change or improve its products or any portions thereof without being obligated to provide such a change or improvement for units sold and/or shipped prior to such change or improvement.

**DISCLAIMER:** Any oral statements about the product made by the seller, the manufacturer, the representatives or any other parties, do not constitute warranties, shall not be relied upon by the user, and are not part of the contract for sale. Seller's and manufacturer's only obligation, and buyer's only remedy, shall be the replacement and/or repair by the manufacturer of the product as described above. Neither seller nor the manufacturer shall be liable for any injury, loss or damage, direct, incidental or consequential (including, but not limited to, incidental or consequential damages for lost profits, lost sales, injury to person or property, or any other incidental or consequential loss), arising out of the use or the inability to use the product, and the user agrees that no other remedy shall be available to it. Before using, the user shall determine the suitability of the product for his intended use, and user assumes all risk of liability whatsoever in connection therewith. The warranty and remedy described in this limited warranty is an EXCLUSIVE warranty and remedy and is IN LIEU OF any other warranty or remedy, expressed or implied, which other warranties and remedies are hereby expressly EXCLUDED, including but not limited to any implied warranty of MERCHANTABILITY OR FITNESS FOR A PARTICULAR PURPOSE. Some states do not allow the exclusive or limitation of incidental or consequential damages, so the above limitation or exclusion may not apply to you. This warranty gives you specific legal rights, and you may also have other rights which vary from state to state.

In the absence of other suitable proof of the installation date, the effective date of this warranty will be based upon the date of manufacture plus one year. Direct all notices, etc., to: Jim Murray, Inc., N116 W18455 Morse Dr., Germantown, WI 53022.

**DETERMINATION OF UNIT DATE OF MANUFACTURE:** (9-87) month and year stamped on pump and/or serial number on pump nameplate coded to indicate year of manufacture.

Figure 2.

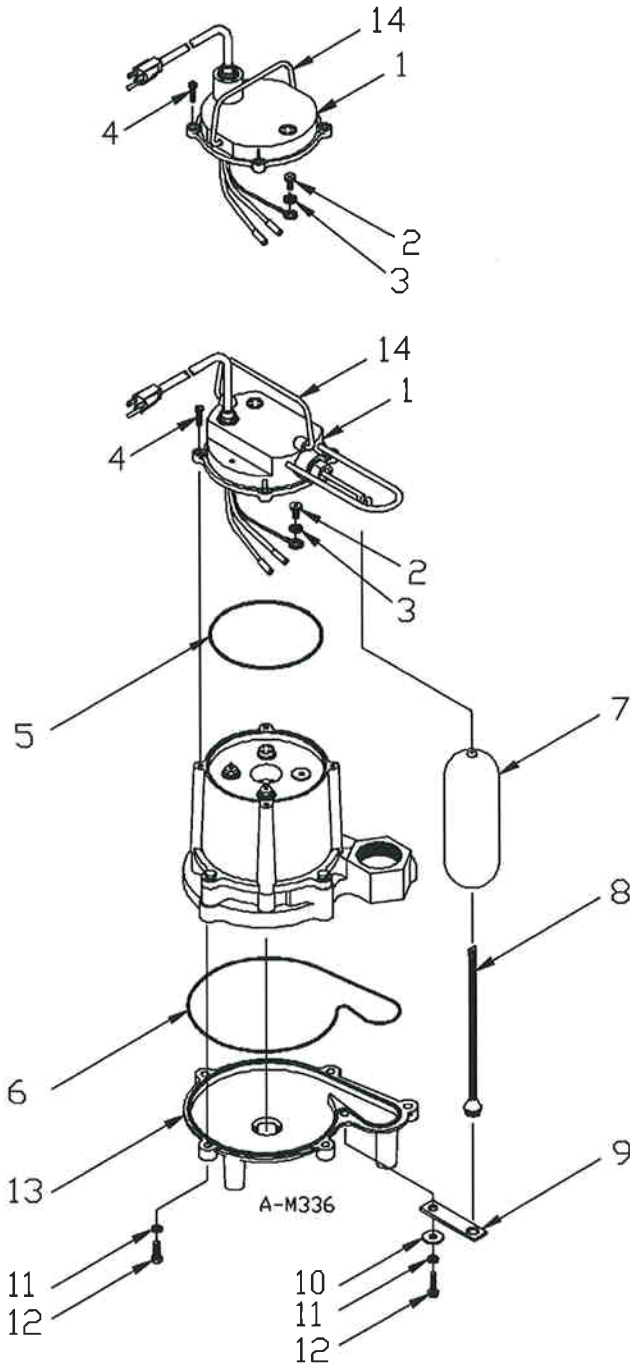

REPLACEMENT PARTS			PVL-ULTRA-MAN	PVL-MAX-SFS
			Qty.	Qty.
Item No.	Part No.	Description		
1	106337	Cover, Black, 10' Cord, Manual	1	
1	106384	Cover, Black, 10' Cord, w/Switch		1
2	902437	Screw, #8-32 x 1/4"	1	1
3	921059	Washer, Lock, #8, Stainless	1	1
4	909022	Screw/Washer, #10-24 x 5/8"	4	4
5	928002	Seal Ring, 4.718" x .078"	1	1
6	928039	Seal Ring, 7.928" x .078"	3	1
7	106362	Float		1
8	106355	Rod, Float		1
9	106354	Strap, Float		1
10	921012	Washer, Plain, 1/4", Stainless		1
11	921103	Washer, Lock, 1/4", Stainless	6	6
12	903725	Screw, Washer, Cap, 3/8-16 x 1-1/4", SST	6	6
13	106389	Screen/Base, Black	1	1
14	108101	Handle	1	1

For Parts, Repair or  
 Technical Assistance, please contact . . . . . 262.253.1353

www.jimmurrayinc.com  
 sales@jimmurrayinc.com

# StormPro 2100-DC

Heavy Duty 12V DC Pump

## OPERATION MANUAL

Dated: 04/24/08

Supersedes: 02/04/08

Document No.: SP2100-OM

Page 1 of 7

# StormPro<sup>®</sup> Heavy Duty 12V DC Pump 2100-DC

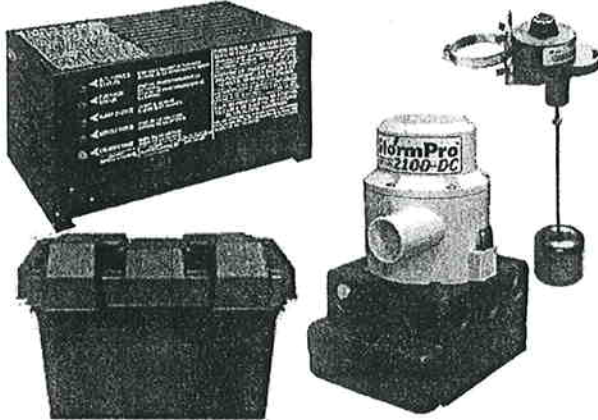

### Important Safety Instructions

READ AND SAVE THESE INSTRUCTIONS  
- THIS MANUAL CONTAINS IMPORTANT INSTRUCTIONS

FAILURE TO HEED SAFETY INSTRUCTIONS  
AND WARNINGS COULD RESULT IN *INJURY OR DEATH*

- Read all the instructions before installing or using the StormPro 2100-DC. Always disconnect batteries and disconnect StormPro 2100-DC from the AC power source before storing, handling, or making any adjustments to the unit.
- Use StormPro 2100-DC only as described in this manual. Any other use not recommended by the manufacturer may cause fire, electric shock, or injury to persons.
- Do not sit or stand on StormPro 2100-DC. Keep children away.
- Do not place objects on StormPro 2100-DC or allow vents to become blocked.
- Do not smoke, use sparkable electrical devices, or open flame when working on this unit!
- Do not install StormPro 2100-DC in locations classified as hazardous per N.E.C., ANSII/NFPA 70 - 1984.



### WARNING: ELECTRICAL SHOCK HAZARD

- This unit has not been evaluated for use outdoors - Never operate StormPro 2100-DC outdoors.
- Never operate StormPro 2100-DC with battery enclosure open.
- Never operate StormPro 2100-DC in a wet location.
- Never operate StormPro 2100-DC in a location where liquid or moisture will come in contact with, splash on, or drip on unit.
- Do not insert or allow foreign objects to enter any ventilation or exhaust opening as this may cause electric shock, and/or a fire hazard.



### WARNING: RISK OF ELECTRICAL SHOCK

In the event of a short circuit, grounding reduces the risk of shock by providing an escape wire for the electrical current. The StormPro 2100-DC must be properly grounded.

The StormPro 2100-DC is equipped with a cord having a grounding wire with an appropriate grounding plug. The plug must be used with an outlet that has been installed and grounded in accordance with all local codes and ordinances. The outlet must be the same configuration as the plug. Where a two-prong wall outlet is encountered, it must be replaced; contact a qualified electrician. To reduce the risk of electric shock, the grounding plug must not be cut off the plug. Do not use the three-prong plug with a two-prong adapter. DO NOT attempt to defeat this safety feature.

Use the StormPro 2100-DC only with adequate wiring that is up to code. Connect to properly grounded outlets only.



### WARNING: RISK OF ELECTRICAL SHOCK

The StormPro 2100-DC is capable of and intended to generate electrical current when unplugged from the wall outlet or when the AC power is shut off.

# StormPro 2100-DC

Heavy Duty 12V DC Pump

## OPERATION MANUAL

Dated: 04/24/08

Supersedes: 02/04/08

Document No.: SP2100-OM

Page 2 of 7

Because the StormPro 2100-DC uses batteries to generate 120 volts of AC current, both the batteries and the power cord must be disconnected to neutralize the StormPro 2100-DC. Failure to disconnect both the batteries and the power cord could result in electrical shock sufficient to cause injury or death.

SEE ALSO "BATTERY PRECAUTIONS".

### Battery Precautions

**WARNING: IMPORTANT SAFETY INSTRUCTIONS. SAVE THESE INSTRUCTIONS.**

A. Servicing of batteries should be performed or supervised by personnel knowledgeable of batteries and the required precautions. Keep unauthorized personnel away from batteries.

B. When replacing batteries, use only models conforming to Battery Council International (BCI) 27 DC specifications for Group 27 Deep Cycle Marine batteries. At the time of this publication, the following model batteries are recommended. At the time of purchase, verify that these models, or any other model, conform to Battery Council International (BCI) 27DC specifications for Group 27 Deep Cycle Marine Batteries:

Die Hard	Model 27524
Exide	Model NC-27
Interstate	Model SRM-27
Metropolitan	Model 27T-36
Metropolitan	Model MT120
Metropolitan AGM	Model LW20104
NAPA	Model 8270

C. **CAUTION** - Do not dispose of batteries in a fire. The batteries may explode.

D. **CAUTION** - Do not open or mutilate the batteries. Released electrolyte is harmful to the skin and eyes. It may be toxic.

E. **CAUTION** - A battery can present a risk of electrical shock and high short circuit current. The following precautions should be observed when working on batteries.

1. Remove watches, rings, or other metal objects.
2. Use tools with insulated handles.

3. Do not lay tools or metal objects on top of batteries.

4. Wear safety goggles and a face shield.

F. **CAUTION** - The electrolyte is a dilute sulfuric acid that is harmful to the skin and eyes. It is electrically conductive and corrosive. The following procedures should be observed:

1. Wear full eye protection and clothing.

2. If electrolyte contacts the skin, wash it off immediately.

3. If electrolyte contacts the eyes, flush thoroughly and immediately with water. Seek medical attention.

4. Spilled electrolyte should be washed down with a suitable acid neutralizing agent. A common practice is to use a solution of approximately one pound (500 grams) bicarbonate of soda to approximately one gallon (4 liters) of water. The bicarbonate of soda solution can be added until the evidence of reaction (foaming) has ceased. The resulting liquid should be flushed with water and the area dried.

G. **CAUTION** - Lead acid batteries can present a risk of fire because they generate oxygen and hydrogen gas. The following procedures should be followed.

1. Do not smoke when near batteries

2. Do not cause flame or spark in battery area.

3. Discharge static electricity from body before touching batteries by first touching a grounded metal surface.

H. See Battery Manufacturers' installation manual for additional installation maintenance, and safety instructions.



# StormPro 2100-DC

Heavy Duty 12V DC Pump

## OPERATION MANUAL

Dated: 04/24/08

Supersedes: 02/04/08

Document No.: SP2100-OM

Page 3 of 7

### Tools Needed

A pipe wrench, pliers, adjustable wrench, pipe cutter, and a screwdriver will be needed.

### Materials Needed

PVC Pipe, appropriate PVC fitting, PVC glue and primer, non restrictive 1 1/2" check valve, and a tape measure.

### Pump Installation

1. Use PVC glue to fasten the pumps 90 degree elbow onto the pumps discharge pipe in an upright position so the discharge is going straight up. Use PVC glue to secure the elbow into place.
2. Screw in the 1 1/8" PVC male adapter fitting into the 90 degree elbow on the pump.
3. Place the pump into the pump base.
4. Place the pump into the basin in a suitable position next to the primary pump and away from the drain tile if possible.
5. Begin to rough in your PVC piping, If you are using a single discharge pipe for both pumps, make sure your PVC Y or 90 degree connection is above the primary check valve. Do not glue any fittings at this point.
6. Make sure to include a separate 1 1/2" check valve for the backup pumps discharge pipe. Do not use spring loaded or any type resistance check valve.
7. Once all of your PVC piping is roughed in and all pipe connections fit flush begin to glue the piping together starting from the pump up. Use only PVC cement and primer.

### Float Switch Installation

1. The backup float switches turn ON point must be above the primary pump float switches ON point and below the top of the basin.
2. Once the backup pump is installed properly attach the backup float switch by tightening the switch clamp securely to the backup pumps discharge pipe.

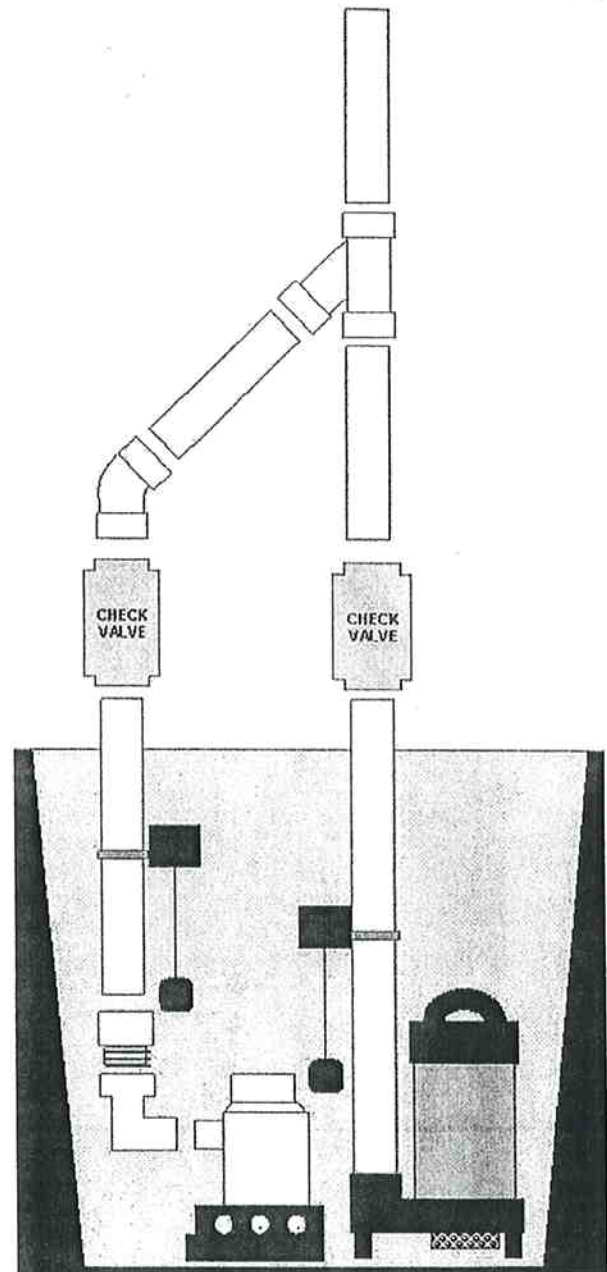

3. Make sure that the float ball on the backup switch will not get caught or hung up on the primary pump or any other object that will restrict the switch from turning on.

# StormPro 2100-DC

Heavy Duty 12V DC Pump

## OPERATION MANUAL

Dated: 04/24/08

Supersedes: 02/04/08

Document No.: SP2100-OM

Page 4 of 7

### Charger Unit Installation

**WARNING:** BE SURE THAT THE CHARGER UNIT IS NOT PLUGGED INTO THE WALL OUTLET BEFORE CONNECTING THE TERMINALS

The backup pump, backup float switch, and battery will all connect into the back of the charger unit. Make sure to use correct polarity.

**PUMP:** Start with the backup pump wires, the terminals are different sizes to ensure correct polarity, do not force the terminal onto the plug. Connect the backup pumps negative (-) black wire to the charger units negative (-) pump post and connect the pumps positive (+) brown wire to the charger units positive (+) pump post.

**FLOAT:** Connect the float switches positive (+) white wire to the chargers positive (+) float post. Connect the float switches negative (-) black wire to the chargers (-) float post.

**BATTERY:** The battery should be placed inside its protective battery box before being connected to the charger unit. Make sure that the charger unit is not plugged into the wall outlet.

1. Take the negative (-) black battery wire and fasten the ring terminal securely to the negative (-) battery post on top of the battery.
2. Take the Positive(+) red battery wire and fasten the ring terminal securely to the Positive(+) battery post on top of the battery.
3. The battery terminals are different sizes to ensure correct polarity, do not force the terminal on to the plug if it does not fit. Connect the negative (-) black wire to the charger units (-) battery post and connect the positive (+) red wire to the charger units positive (+) battery post.
4. After all the terminals have been installed properly plug the charger unit into a dedicated 115V wall outlet.

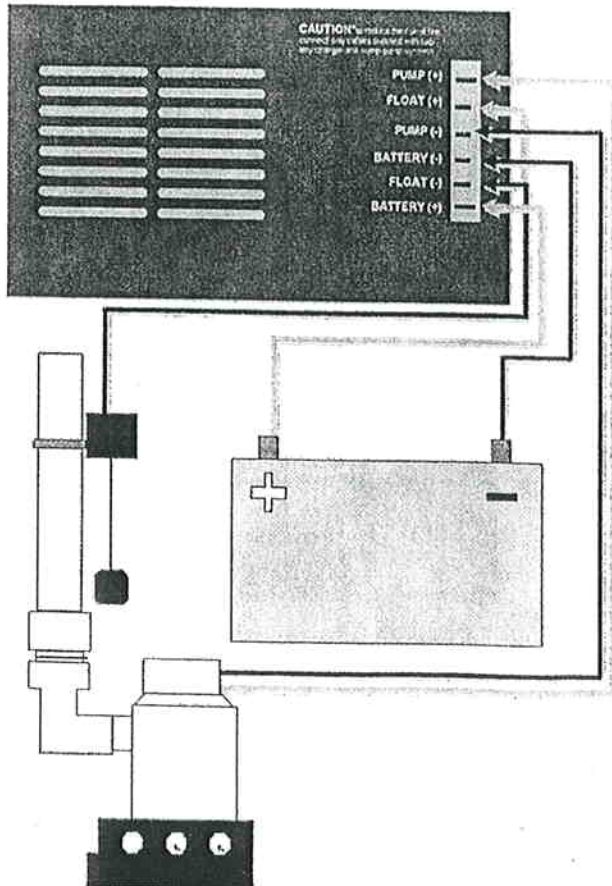



# StormPro 2100-DC

Heavy Duty 12V DC Pump

## OPERATION MANUAL

Dated: 04/24/08

Supersedes: 02/04/08

Document No.: SP2100-OM

Page 5 of 7

Error Description	Possible Causes	Fix
The battery failed pre-qualification test	The battery is highly sulfated The charger is connected to a six-volt battery	Replace the battery with a 12-volt deep-cycle marine battery Replace the battery with a 12-volt deep-cycle marine battery
Battery over-voltage	The charger is connected to a 24 volt battery	Replace the battery with a 12-volt deep-cycle marine battery
Charge time monitor	Battery took too long to complete its charge: A. Load applied (e.g. the pump motor started) during charging B. The battery ampere-hour rating is too large (max. 130 ampere-hours)	Be sure the pump cannot start during charging; reset the charger Replace with correct size battery
Excessive battery drain	Pump motor ran during charging (that is, with the main A.C. power ON), causing the system to shut down	Check primary sump pump. The BBU generally runs only when the main A.C. power is out. If there has not been any power outage and the BBU has run, the primary pump itself may have failed
Reverse battery connection	Charger is connected backwards to the battery. (That is, charger (+) to battery (-) and vice versa)	Reconnect charger (+) to battery (-)/(-) to (-)
Battery overheated	Cells in an old battery may deteriorate with age	Replace the battery with a 12-volt deep-cycle marine battery
Charging error	An internal error occurred in the charger during one of the charging states	Unplug the charger for 10 seconds and then plug it in again. If error occurs again, refer to table below

### Amp Charger Error Light Indications

**NOTE:** This chart identifies light codes indicating various charger error modes. It **only** applies when the 'Charger Mode' light flashes YELLOW/GREEN alternately. The light codes listed here DO NOT relate

directly to the legends on the charger housing (A.C. Power Status, Pump Run Status, Alarm Silence, etc.). The legends on the charger apply **ONLY** when the 'Charger Mode' light is **NOT** flashing yellow/green.

LED Status				
A.C. Power Status	Pump Run Status	Alarm Silence	Charge Mode	Error Mode
Flashing	Off	Off	Flashing Yellow/Green	Battery Overheated
Flashing	Off	Flashing	Flashing Yellow/Green	Charge Time Monitor
Flashing	Flashing	Off	Flashing Yellow/Green	Excessive Battery Drain
Flashing	Flashing	Flashing	Flashing Yellow/Green	Failed Pre-Qualification Test
Off	Off	Flashing	Flashing Yellow/Green	Battery Over-Voltage
Off	Flashing	Off	Flashing Yellow/Green	Reverse Battery Connection
Off	Flashing	Flashing	Flashing Yellow/Green	Output Over-Current

#### "Silence Alarm/Reset" Rocker Switch:

Push The LEFT side of the rocker switch on the front of the charger to silence the alarm. **NOTE:** This will NOT silence the alarm when the battery is below 8.2 volts or the system is in ERROR mode.

Push the RIGHT side of the rocker switch to reset the 'Pump System Status' LED after the pump has

run, or to reset the system from an error mode. When you reset the system, the charger will start its diagnostic procedure (pre-qualification test, etc.) from the beginning. If the cause of the ERROR mode is not corrected, the system will go into the ERROR mode again.



# StormPro 2100-DC

Heavy Duty 12V DC Pump

## OPERATION MANUAL

Dated: 04/24/08

Supersedes: 02/04/08

Document No.: SP2100-OM

Page 6 of 7

Charger Light	On/Off/Flashing	Alarm Buzzer	Indicates
All LEDs	Flash ONCE	Off	Connected system to AC power or to battery; or, pressed 'Reset' when in ERROR mode
AC Power Status	On Very Slow Flash	Off Off	System is receiving AC power System is not receiving AC power
Pump Run Status	Fast Flash (2x/second) Slow Flash (1x/2 seconds) Off	Beep in synch with LED Flash Off Off	Pump is running. Press LEFT side of rocker switch to silence alarm Pump has run, but is not running now Pump has not run
Alarm Silence	On Off		Alarm is silenced Alarm is active
Battery Status	On  Slow Flash Fast Flash  Off	Off  On On  Off	System is not connected to a battery or is connected to a battery charged to less than 1 volt DC Battery voltage less than 10.9 volts. Alarm can be silenced Battery voltage is less than 8.2 volts. Alarm CANNOT be silenced System is properly connected to a battery
Charger Mode	Slow YELLOW Flash  Solid YELLOW Flash  Fast YELLOW Flash  Solid GREEN Flashing alternately YELLOW/GREEN	Off  Off  Off  Off On - Beeping	System is in "pre-qualification" stage. This will last from 1 minute to 5 hours, depending on the condition of your battery System is in the "Constant Current Charge" stage. This will continue until the battery voltage reaches approximately 14.3 volts System is in the "Constant Voltage Charge" stage. This could last up to 14.5 hours Battery is fully charged System is in ERROR mode. Alarm will beep in synch with one or more of the 'AC Power Status', 'Pump Run Status', or 'Alarm Silence' LEDs.

### Amp Charger Audio Alarm Indications

Audio Alarm	Mode	Indicates	Action
On - Beeping	Slow beep in synch with 'Battery Status' LED	Battery is down to about 10.9 volts	Investigate cause; battery is very low. You have limited pump run time left. Press and release LEFT side of toggle switch to silence alarm.
On - Beeping	Fast beep in synch from 'Battery Status' LED	Battery is down to about 8.2 volts	Investigate cause; battery is nearly dead. You have almost no pump run time left. Alarm CANNOT be silenced
On - Beeping	Fast beep in synch with one or more of the 'AC Power Status', 'Pump Run Status', or 'Alarm Silence' LEDs and with the 'Charger Mode' LED flashing alternately YELLOW/GREEN	System is in ERROR mode	Refer to ERROR Mode Charts
On - Beeping	Fast beep in synch with 'Pump Run Status' LED	Pump is running	None. Alarm will stop when pump stops running. To silence alarm, press and release LEFT side of toggle switch



**Metropolitan Industries, Inc.**  
www.metropolitanind.com

# StormPro 2100-DC

Heavy Duty 12V DC Pump

## OPERATION MANUAL

Dated: 04/24/08

Supersedes: 02/04/08

Document No.: SP2100-OM

Page 7 of 7

### LIMITED WARRANTY

StormPro 2100-DC is warranted to be free from defects in material and workmanship and to perform within applicable specifications for a period of one (1) year. Obligation under this warranty is limited to repairing or replacing any part thereof, which shall within one year be returned to us with transportation charges prepaid, and prove to be defective.

The above limited warranty takes the place of all other warranties, express or implied and correction of such defects by replacement or repair shall constitute a fulfillment of all obligations under the terms of the warranty, which specifically EXCLUDES any incidental damages caused by or associated with this product or its use. The warranty does not cover any unit which has been damaged either in transit or by misuse, accident or negligence. No warranty or representation not contained herein shall be binding.

LABOR, ETC. COSTS: Metropolitan shall IN NO EVENT be responsible or liable for the cost of field labor or other charges incurred by any customer in removing and/or affixing any Metropolitan product, part or component thereof.

#### STORMPRO 2100-DC WARRANTY REGISTRATION CARD

To register your purchase, please fill in the following information:

Please fill out and  
send back to:

Metropolitan Ind.  
Warranty Department  
P.O. Box 7266  
Romeoville, IL 60446

Name: \_\_\_\_\_ Date: \_\_\_\_\_

Address: \_\_\_\_\_

City: \_\_\_\_\_ State: \_\_\_\_\_ Zip: \_\_\_\_\_

Purchased From: \_\_\_\_\_

Installed By: \_\_\_\_\_ Phone: \_\_\_\_\_



**Metropolitan Industries, Inc.**  
www.metropolitanind.com