

## 12 Volt, Maintenance Free, Deep Cycle Battery Model AZP-BATTERY-SL



### AZP-BATTERY-SL Features

- Designed to deliver premium service in on-charge applications:
  - Trickle chargers
  - AC/DC inverters
- Utilizes calcium alloys and glass mat positive plate separators for reliable service
- Premium quality and performance
- Maintenance free
- Built in hydrometer
- Built in, heavy duty handle
- Lasts twice as long as a typical battery
- Warranty: 1st Year Limited – 2nd Year Pro-Rated

### Electrical Specifications:

<b>Voltage:</b>	<b>12 Volts</b>	
<b>Reserve Capacity:</b>	<b>185 Minutes</b>	
<b>Amp Hour Capacity:</b>	<b>20 Hour Rate (6.5A)</b>	<b>130 AH</b>
	<b>10 Hour Rate (11.5A)</b>	<b>115 AH</b>
	<b>5 Hour Rate (17.6A)</b>	<b>88 AH</b>
	<b>3 Hour Rate (25.0A)</b>	<b>75 AH</b>

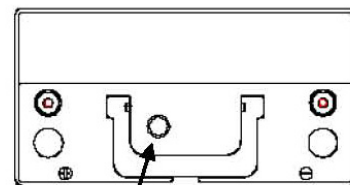

One-Ball PROeye™ Hydrometer

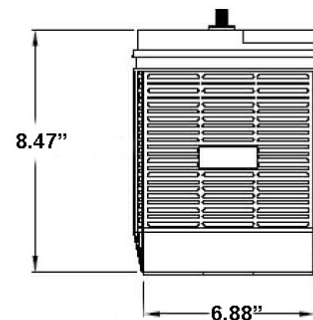

### Specifications:

<b>Physical Characteristics:</b>	<b>Length</b>	<b>13.13"</b>
	<b>Width</b>	<b>6.88"</b>
	<b>Height</b>	<b>9.38"</b>
	<b>Weight</b>	<b>62 lbs</b>

